

Single N-Channel MOSFET

DESCRIPTION

SMC3332SN is the N-Channel enhancement mode power field effect transistors are using trench DMOS technology. This advanced trench technology devices are well suited for high efficiency fast switching applications, low in-line power loss are needed in small outline surface mount package.

PART NUMBER INFORMATION

SMC 3332 SN - TR G
 a b c d e

- a : Company name.
- b : Product Serial number.
- c : Package code SN: SOT-23
- d : Handling code TR: Tape&Reel
- e : Green produce code G: *RoHS Compliant*

FEATURES

$V_{DS}=30V$, $I_D=5.4A$

$R_{DS(ON)}=22m\Omega(Typ.)@V_{GS}=10V$
 $R_{DS(ON)}=26m\Omega(Typ.)@V_{GS}=4.5V$
 $R_{DS(ON)}=38m\Omega(Typ.)@V_{GS}=2.5V$

- ◆ Fast switch
- ◆ 2.5V Low gate drive applications

APPLICATIONS

- ◆ Hand-Held Instruments
- ◆ Load Switch
- ◆ LED Applications



SOT-23

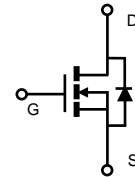

ABSOLUTE MAXIMUM RATINGS ($T_A = 25^\circ C$ Unless otherwise noted)

Symbol	Parameter	Rating	Units
V_{DSS}	Drain-Source Voltage	30	V
V_{GSS}	Gate-Source Voltage	± 12	V
I_D	Continuous Drain Current ^A	$T_A=25^\circ C$	5.4
		$T_A=70^\circ C$	4.3
I_{DM}	Pulsed Drain Current ^B	22	A
I_{AS}	Avalanche Current ^B	8	A
E_{AS}	Single Pulse Avalanche energy $L=0.1mH$ ^B	3.2	mJ
P_D	Power Dissipation ^A	$T_A=25^\circ C$	1.3
		$T_A=70^\circ C$	0.8
T_J	Operation Junction Temperature	-55/150	$^\circ C$
T_{STG}	Storage Temperature Range	-55/150	$^\circ C$

THERMAL RESISTANCE

Symbol	Parameter	Typ	Max	Units
$R_{\theta JA}$	Thermal Resistance Junction to Ambient ^A	$t \leq 10s$	95	$^\circ C/W$
	Thermal Resistance Junction to Ambient ^{AC}	Steady-State	130	

ELECTRICAL CHARACTERISTICS ($T_A = 25^\circ\text{C}$ Unless otherwise noted)

Symbol	Parameter	Condition	Min	Typ	Max	Unit
Static Parameters						
BV _{DSS}	Drain-Source Breakdown Voltage	V _{GS} =0V, I _D =250 μ A	30			V
V _{GS(th)}	Gate Threshold Voltage	V _{DS} =V _{GS} , I _D =250 μ A	0.5	0.7	1	V
I _{GSS}	Gate Leakage Current	V _{DS} =0V, V _{GS} = \pm 12V			\pm 100	nA
I _{DSS}	Zero Gate Voltage Drain Current	V _{DS} =30V, V _{GS} =0V, T _J =25 $^\circ$ C			1	μ A
		V _{DS} =24V, V _{GS} =0V, T _J =75 $^\circ$ C			10	
R _{DS(ON)}	Drain-source On-Resistance ^D	V _{GS} =10V, I _D =5.4A		22	26	m Ω
		V _{GS} =4.5V, I _D =3.6A		26	32	
		V _{GS} =2.5V, I _D =2.5A		38	48	
G _{fs}	Forward Transconductance	V _{DS} =10V, I _D =3A		7		S
Diode Characteristics						
V _{SD}	Diode Forward Voltage ^D	I _S =1A, V _{GS} =0V			1	V
I _S	Diode Continuous Forward Current				2.7	A
Dynamic and Switching Parameters^E						
Q _g	Total Gate Charge	V _{DS} =15V, V _{GS} =10V, I _D =5A		11.3	15.8	nC
Q _g	Total Gate Charge(4.5V)			5.5	7.7	
Q _{gs}	Gate-Source Charge			1.43	2	
Q _{gd}	Gate-Drain Charge			1.6	2.2	
C _{iss}	Input Capacitance	V _{DS} =15V, V _{GS} =0V, f=1MHz		450		pF
C _{oss}	Output Capacitance			85		
C _{rss}	Reverse Transfer Capacitance			53		
t _{d(on)}	Turn-On Time	V _{DD} =15, V _{GEN} =10V R _G =6 Ω , I _D =1A		4.25	8	nS
t _r				15.8	30	
t _{d(off)}	Turn-Off Time			31	59	
t _f				9.2	17	

Note: Absolute maximum ratings are those values beyond which the device could be permanently damaged.

- A. Surface mounted on FR4 board using 1 in² pad size.
- B. Pulsed width limited by maximum junction temperature, T_{J(MAX)}=150 $^\circ$ C.
- C. Using \leq 10s junction-to-ambient thermal resistance is base on T_{J(MAX)}=150 $^\circ$ C.
- D. Pulse test width \leq 300 μ s and duty cycle \leq 2%.
- E. Guaranteed by design, not subject to production testing.

The products and product specifications contained herein are subject to change without notice to improve performance characteristics. Consult us, or our representatives before use, to confirm that the information in this datasheet is up to date. We assume no responsibility for any infringement of patents, patent rights, or other rights arising from the use of any information and circuitry in this datasheet.

TYPICAL CHARACTERISTICS

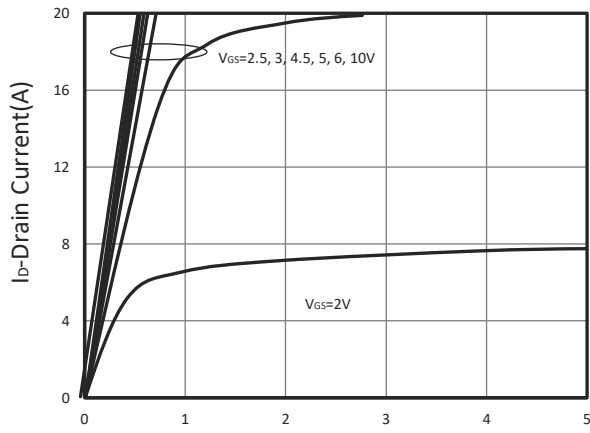

V_{DS}-Drain Source Voltage(V)
Output Characteristics

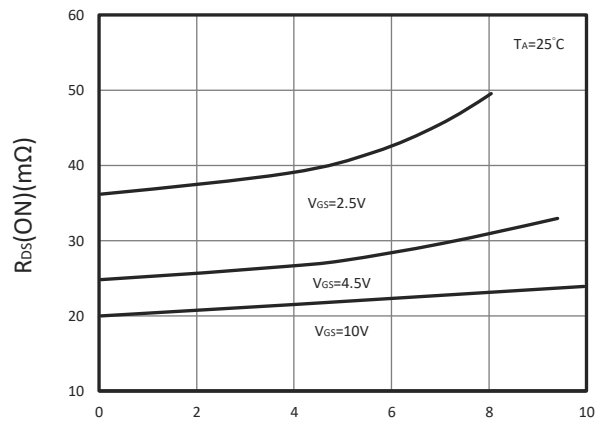

I_D-Drain Current(A)
Drain-Source On Resistance

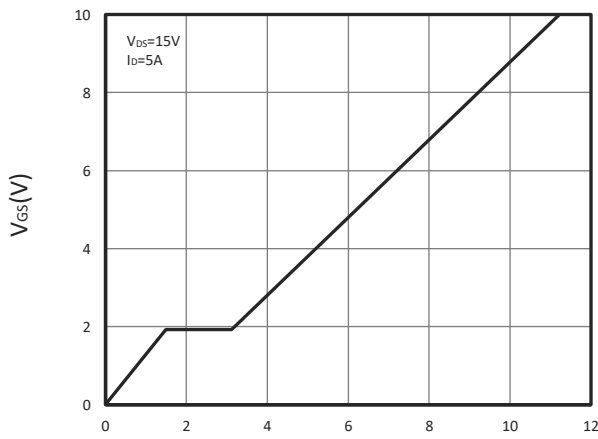

Q_G-Gate Charge(nC)
Gate Charge

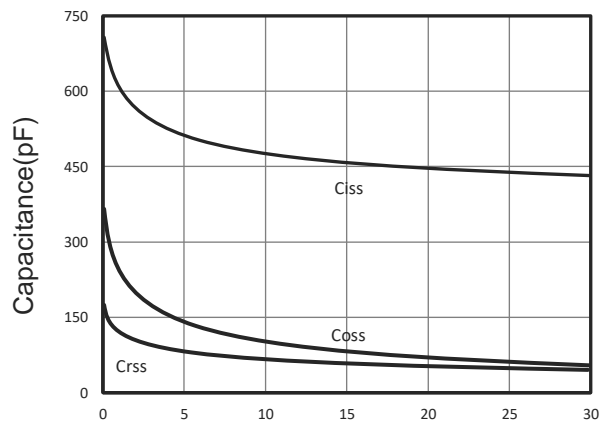

Capacitance

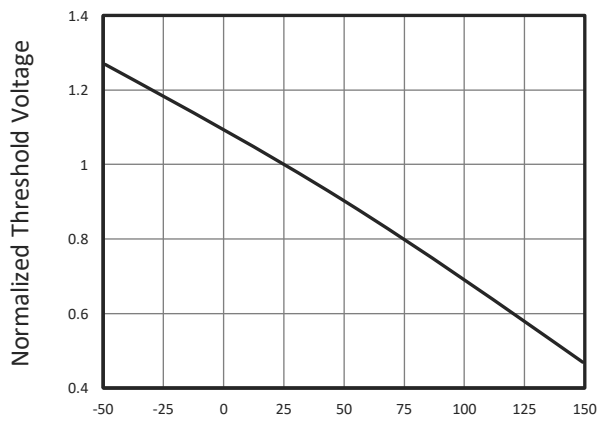

T_J-Junction Temperature(°C)
Gate Threshold Voltage

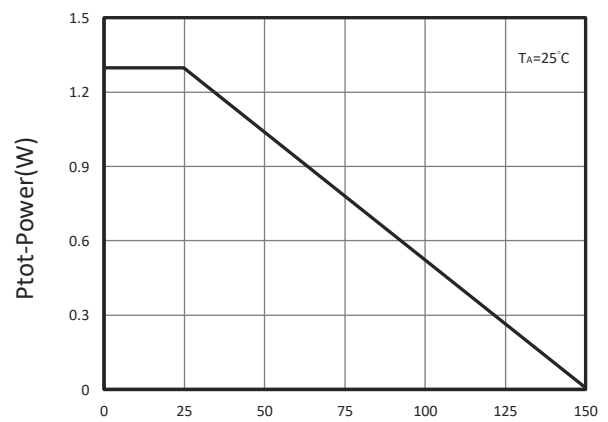

T_J-Junction Temperature(°C)
Power Dissipation

TYPICAL CHARACTERISTICS

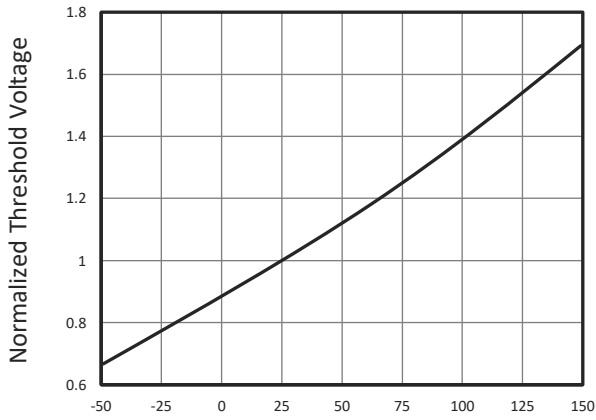

T_J-Junction Temperature(°C)
Gate Threshold Voltage

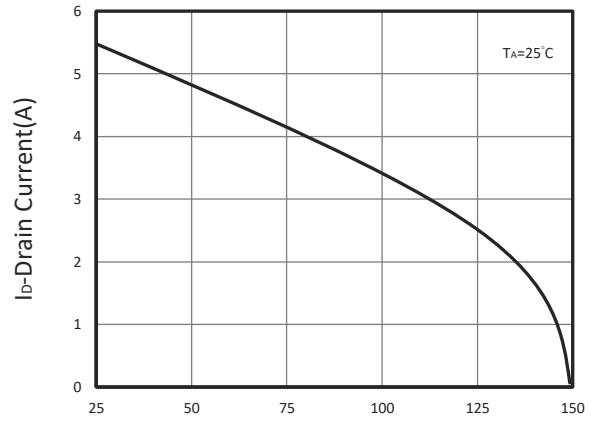

T_J-Junction Temperature(°C)
Drain Current vs T_J

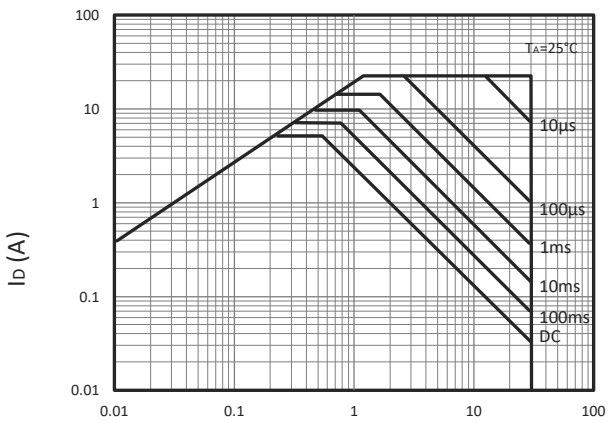

V_{DS} Voltage (V)
Maximum Safe Operation Area

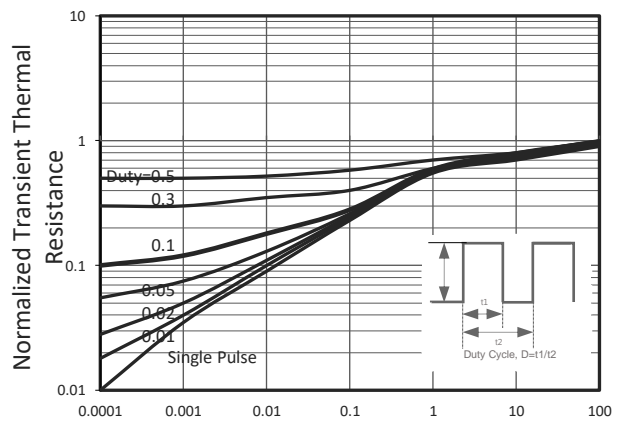

Square Wave Pulse Duration(Sec)
Thermal Transient Impedance

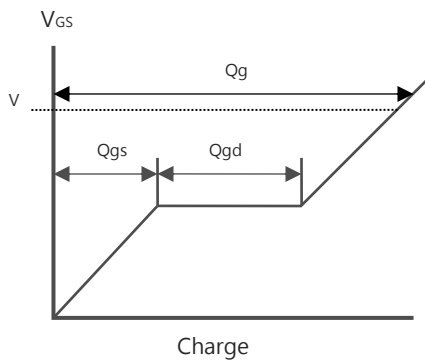

Gate Charge Waveform

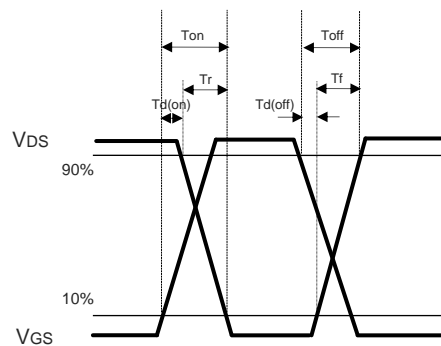

Switching Time Waveform

■ SOT-23 PACKAGE DIMENSIONS

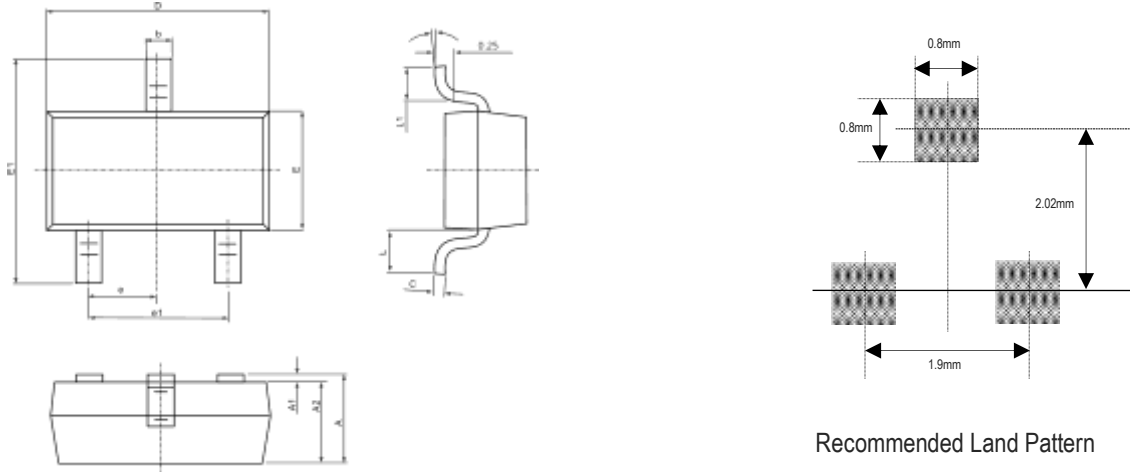

Symbol	Dimensions In Millimeters		Dimensions In Inches	
	Min.	Max.	Min.	Max.
A	0.900	1.150	0.035	0.045
A1	0.000	0.100	0.000	0.004
A2	0.900	1.050	0.035	0.041
b	0.300	0.500	0.012	0.020
c	0.080	0.150	0.003	0.006
D	2.800	3.000	0.110	0.118
E	1.200	1.400	0.047	0.055
E1	2.250	2.550	0.089	0.100
e	0.950 TYP.		0.037 TYP	
e1	1.800	2.000	0.071	0.079
L	0.550 REF.		0.022 REF.	
L1	0.300	0.500	0.012	0.020
θ	0°	8°	0°	8°