

## Single P-Channel MOSFET

### DESCRIPTION

SMC2351SN is the P-Channel enhancement mode power field effect transistors are using trench DMOS technology. This advanced trench technology devices are well suited for high efficiency fast switching applications.

### PART NUMBER INFORMATION

**SMC 2351 SN - TR G**  
 a      b      c      d      e

- a : Company name.
- b : Product Serial number.
- c : Package code      SN: SOT-23
- d : Handling code      TR: Tape&Reel
- e : Green produce code G: *RoHS Compliant*

### FEATURES

**$V_{DS}=-20V$ ,  $I_D=-4.2A$**

- $R_{DS(ON)}=35m\Omega(Typ.)@V_{GS}=-10V$
- $R_{DS(ON)}=43m\Omega(Typ.)@V_{GS}=-4.5V$
- $R_{DS(ON)}=57m\Omega(Typ.)@V_{GS}=-2.5V$
- $R_{DS(ON)}=80m\Omega(Typ.)@V_{GS}=-1.8V$

- ◆ Fast switch
- ◆ 1.8V Low gate drive applications
- ◆ High power and current handling capability

### APPLICATIONS

- ◆ Hand-Held Instruments
- ◆ Load Switch

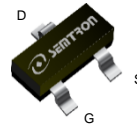

SOT-23

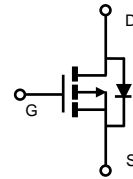

### ABSOLUTE MAXIMUM RATINGS ( $T_A = 25^\circ C$ Unless otherwise noted)

Symbol	Parameter	Rating	Units
$V_{DSS}$	Drain-Source Voltage	-20	V
$V_{GSS}$	Gate-Source Voltage	$\pm 12$	V
$I_D$	Continuous Drain Current <sup>A</sup> ( $V_{GS}=4.5V$ )	$T_A=25^\circ C$	-4.2
		$T_A=70^\circ C$	-3.4
$I_{DM}$	Pulsed Drain Current <sup>B</sup>	16.8	A
$I_{AS}$	Avalanche Current <sup>B</sup>	10	A
$E_{AS}$	Single Pulse Avalanche energy $L=0.1mH$ <sup>B</sup>	5	mJ
$P_D$	Power Dissipation <sup>A</sup>	$T_A=25^\circ C$	1.3
		$T_A=70^\circ C$	0.8
$-T_J$	Operation Junction Temperature	-55/150	$^\circ C$
$T_{STG}$	Storage Temperature Range	-55/150	$^\circ C$

### THERMAL RESISTANCE

Symbol	Parameter	Typ	Max	Units
$R_{\theta JA}$	Thermal Resistance Junction to Ambient <sup>A</sup>	$t \leq 10s$	95	$^\circ C/W$
	Thermal Resistance Junction to Ambient <sup>AC</sup>	Steady-State	130	

## ELECTRICAL CHARACTERISTICS ( $T_A = 25^\circ\text{C}$ Unless otherwise noted)

Symbol	Parameter	Condition	Min	Typ	Max	Unit
<b>Static Parameters</b>						
BV <sub>DSS</sub>	Drain-Source Breakdown Voltage	V <sub>GS</sub> =0V, I <sub>D</sub> =-250 $\mu$ A	-20			V
V <sub>GS(th)</sub>	Gate Threshold Voltage	V <sub>DS</sub> =V <sub>GS</sub> , I <sub>D</sub> =-250 $\mu$ A	-0.5	-0.7	-1	V
I <sub>GSS</sub>	Gate Leakage Current	V <sub>DS</sub> =0V, V <sub>GS</sub> = $\pm$ 12V			$\pm$ 100	nA
I <sub>DSS</sub>	Zero Gate Voltage Drain Current	V <sub>DS</sub> =-20V, V <sub>GS</sub> =0V, T <sub>J</sub> =25 $^\circ$ C			-1	$\mu$ A
		V <sub>DS</sub> =-16V, V <sub>GS</sub> =0V, T <sub>J</sub> =75 $^\circ$ C			-10	
R <sub>DS(ON)</sub>	Drain-source On-Resistance <sup>D</sup>	V <sub>GS</sub> =-10V, I <sub>D</sub> =-4.5A		35	40	m $\Omega$
		V <sub>GS</sub> =-4.5V, I <sub>D</sub> =-4.2A		43	50	
		V <sub>GS</sub> =-2.5V, I <sub>D</sub> =-2.5A		57	68	
		V <sub>GS</sub> =-1.8V, I <sub>D</sub> =-2A		80	95	
G <sub>fs</sub>	Forward Transconductance	V <sub>DS</sub> =-10V, I <sub>D</sub> =-3A		8		S
<b>Diode Characteristics</b>						
V <sub>SD</sub>	Diode Forward Voltage <sup>D</sup>	I <sub>S</sub> =-1A, V <sub>GS</sub> =0V			-1	V
I <sub>S</sub>	Diode Continuous Forward Current				-1.4	A
<b>Dynamic and Switching Parameters <sup>E</sup></b>						
Q <sub>g</sub>	Total Gate Charge	V <sub>DS</sub> =-10V, V <sub>GS</sub> =-4.5V I <sub>D</sub> =-4.2A		7.2	10.1	nC
Q <sub>gs</sub>	Gate-Source Charge			1.2	1.7	
Q <sub>gd</sub>	Gate-Drain Charge			3	4.2	
C <sub>iss</sub>	Input Capacitance	V <sub>DS</sub> =-10V, V <sub>GS</sub> =0V, f=1MHz		650		pF
C <sub>oss</sub>	Output Capacitance			95		
C <sub>rss</sub>	Reverse Transfer Capacitance			62		
t <sub>d(on)</sub>	Turn-On Time	V <sub>DD</sub> =-10V, V <sub>GEN</sub> =-4.5V R <sub>G</sub> =6 $\Omega$ , I <sub>D</sub> =-1A		8.5	16	nS
t <sub>r</sub>				13.3	25	
t <sub>d(off)</sub>	Turn-Off Time			32	61	
t <sub>f</sub>				25	48	

Note: Absolute maximum ratings are those values beyond which the device could be permanently damaged.

- A. Surface mounted on FR4 board using 1 in<sup>2</sup> pad size.
- B. Pulsed width limited by maximum junction temperature, T<sub>J(MAX)</sub>=150 $^\circ$ C (initial temperature T<sub>J</sub>=25 $^\circ$ C).
- C. Using  $\leq$  10s junction-to-ambient thermal resistance is base on T<sub>J(MAX)</sub>=150 $^\circ$ C.
- D. Pulse test width  $\leq$ 300 $\mu$ s and duty cycle  $\leq$  2%.
- E. Guaranteed by design, not subject to production testing.

The products and product specifications contained herein are subject to change without notice to improve performance characteristics. Consult us, or our representatives before use, to confirm that the information in this datasheet is up to date. We assume no responsibility for any infringement of patents, patent rights, or other rights arising from the use of any information and circuitry in this datasheet.

## TYPICAL CHARACTERISTICS

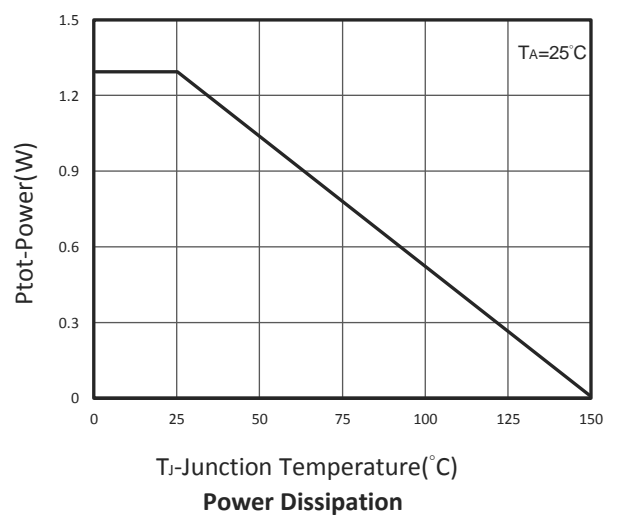
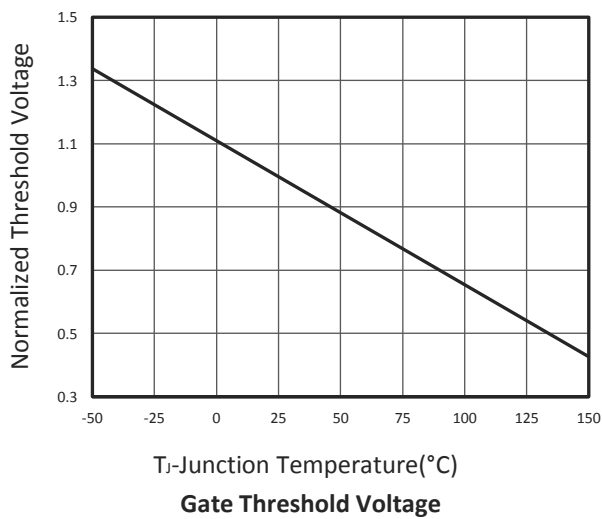
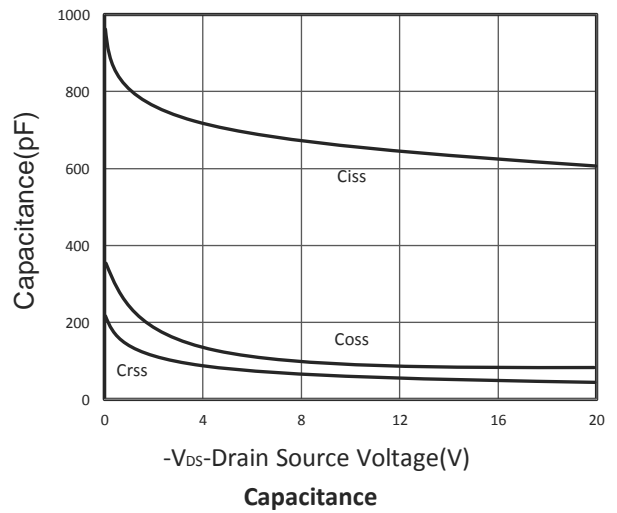
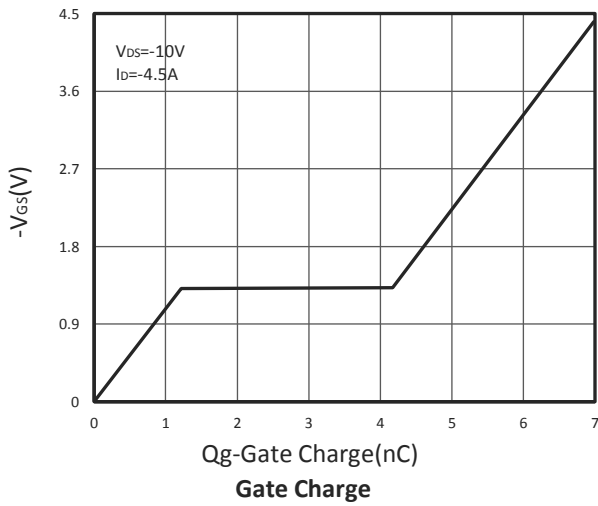
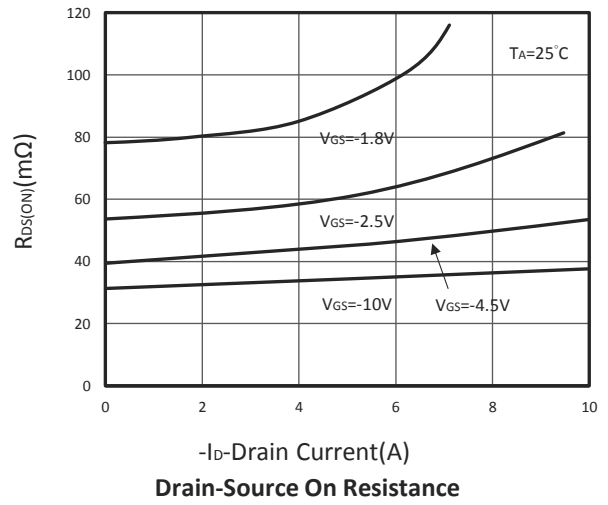
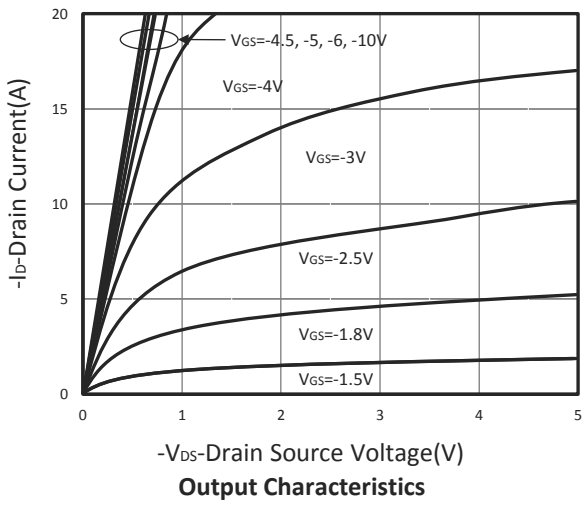

## TYPICAL CHARACTERISTICS

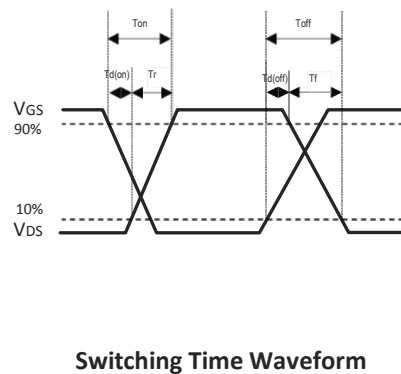
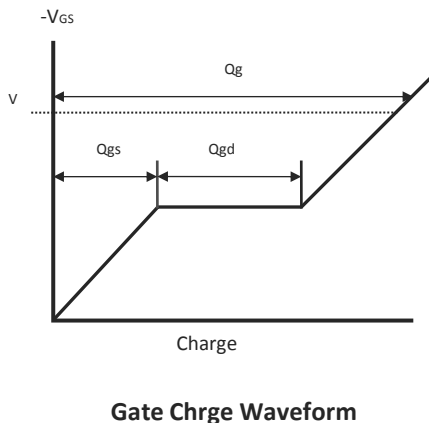
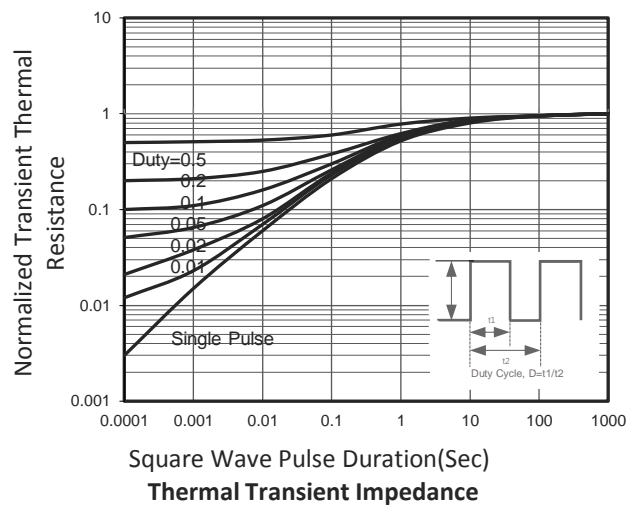
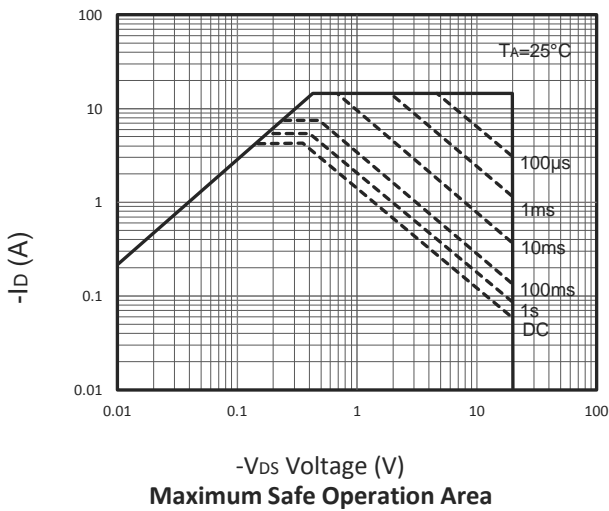
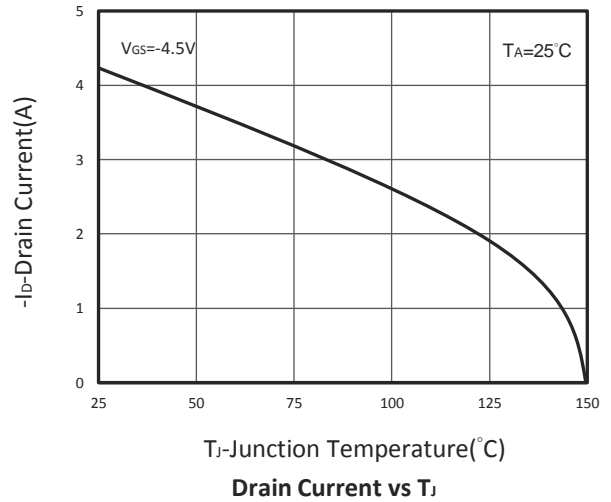
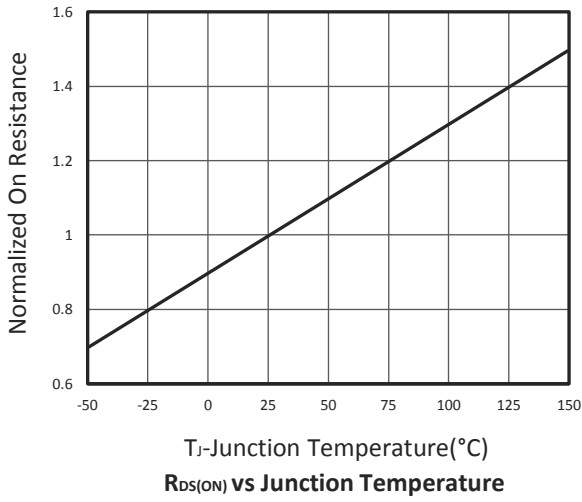

## ■ SOT-23 PACKAGE DIMENSIONS

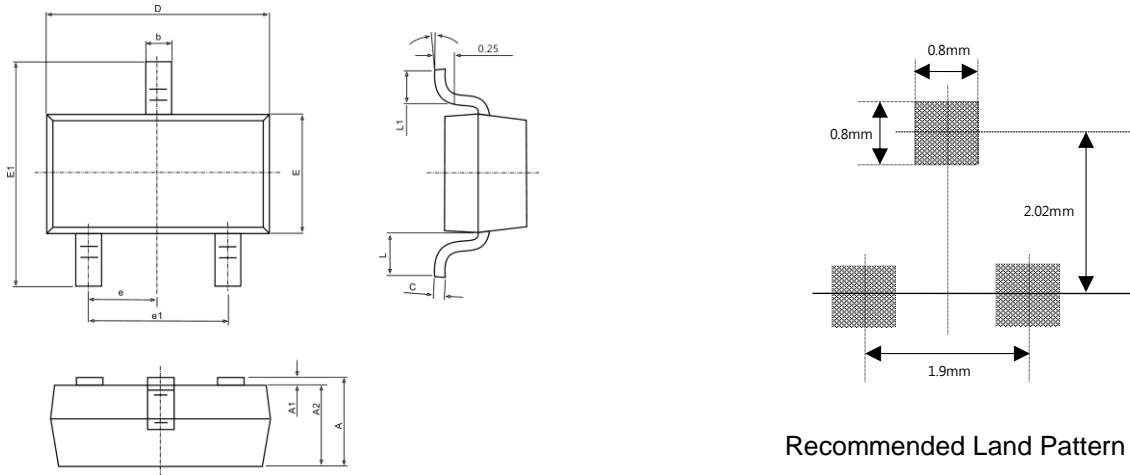

Recommended Land Pattern

Symbol	Dimensions In Millimeters		Dimensions In Inches	
	Min.	Max.	Min.	Max.
A	0.900	1.150	0.035	0.045
A1	0.000	0.100	0.000	0.004
A2	0.900	1.050	0.035	0.041
b	0.300	0.500	0.012	0.020
c	0.080	0.150	0.003	0.006
D	2.800	3.000	0.110	0.118
E	1.200	1.400	0.047	0.055
E1	2.250	2.550	0.089	0.100
e	0.950 TYP.		0.037 TYP	
e1	1.800	2.000	0.071	0.079
L	0.550 REF.		0.022 REF.	
L1	0.300	0.500	0.012	0.020
$\theta$	0°	8°	0°	8°