

300mA Linear Regulator With Fast Enable and Soft Start

DESCRIPTION

The STL6121 series is a low-dropout linear regulator with ON/OFF control that operates in the input voltage range from +2.4V to +9.0V and delivers 300mA output current.

The STL6121 is available fixed output voltage type is preset at an internally trimmed voltage 1.8V, 2.5V, or 3.3V. Other options 1.0V, 1.2V, 1.5V, 2.85V, 3.0V and 3.6V are available by special order only.

The STL6121 series consists of a 0.95V bandgap reference, an error amplifier, and a P-channel pass transistor. Other features include soft start function, short-circuit protection and thermal shutdown protection. The STL6121 series devices are available in SOT-25 packages.

FEATURE

- ◆ Low Current Consumption: 60µA
- ◆ Short Circuit Protection: 150mA
- ◆ Typical Dropout Voltage: 300mV@300mA
- ◆ Fast Response in Power-on Transient
- ◆ Output Current Limit Protection: 600mA
- ◆ Thermal Overload Shutdown Protection
- ◆ Control Output ON/OFF Function
- ◆ High Ripple Rejection: 65dB (Typ.)

APPLICATIONS

- ◆ Battery Powered Equipment.
- ◆ PC Peripherals
- ◆ Portable Electronics
- ◆ Wireless Devices
- ◆ Mobile Phone, Coreless Phone

Low Dropout Regulator

PIN CONFIGURATION

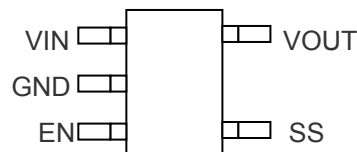

TOP VIEW
SOT-23-5

PART MARKING INFORMATION

<p>STL6121-XX XX-XX X</p> <div style="margin-left: 40px;"> <p>└─ Lead Plating Code</p> <p>└─ Handling Code</p> <p>└─ Package Code</p> <p>└─ Voltage Code</p> </div> <p>Lead Plating Code G : Lead-free product. This product is RoHS compliant</p> <p>Handling Code TR : Tape&Reel TB : Tape&Box</p> <p>Package Code S5 : SOT-25</p> <p>Voltage Code XX : 15 / 18 / 25 / 285 / 30 / 33</p>	<p>Marking:</p> <div style="text-align: center; border: 1px solid black; width: 100px; margin: 10px auto; padding: 5px;">4VAXX</div> <p>SOT-25</p> <p>4 : STL6121 V : Voltage code 8:1.5V, A:1.8V G:2.5V, L:2.85 M:3.0V, Q:3.3V A : Enable Function XX: Date code</p>
--	--

■ ORDERING INFORMATION

Part Number	SOT-25	Package Code	Package	VOUT Voltage	Shipping
STL6121-XXS5-TRG		S5	SOT-25	1.5 1.8 2.5 2.85 3.0 3.3	3000/Tape&Reel

Note:

※“XX”stands for output voltages.

※ G : Lead-free & Halogen-free product.

■ ABSOLUTE MAXIMUM RATINGS ($T_A = 25^{\circ}\text{C}$ Unless otherwise noted)

Parameter	Symbol	Maximum	Unit
Power Dissipation	P_D	400	mW
Input voltage	V_{IN}	9.0	V
Output Current Limit	I_{OUT}	600	mA
Thermal resistance junction to case	θ_{JA}	250	$^{\circ}\text{C}/\text{W}$
Operating Junction Temperature Range	T_J	+155	$^{\circ}\text{C}$
Storage Temperature Range	T_{STG}	-55~+150	$^{\circ}\text{C}$
Lead Soldering Temperature	T_{LEAD}	+260	$^{\circ}\text{C}$

Note: Exceeding these ratings could cause damage to the device. All voltages are with respect to Ground. Currents are positive into, negative out of the specified terminal.

ELECTRICAL CHARACTERISTICS ($T_A = 25^\circ\text{C}$ Unless otherwise noted)

 Operating conditions: $V_{IN}=5\text{V}$, $T_A=25^\circ\text{C}$, unless otherwise noted

Parameter	Symbol	Test Conditions	Min	Typ	Max	Unit
Input Voltage	V_{IN}	-	2.4	-	7.0	V
Output Voltage	V_{OUT}	$V_{IN}=V_{OUT}+1\text{V}$, $I_{OUT}=1\text{mA}$ $V_{OUT} \geq 1.8\text{V}$	2%	V_{OUT}	2%	V
		$V_{IN}=V_{OUT}+1\text{V}$, $I_{OUT}=1\text{mA}$ $V_{OUT} < 1.8\text{V}$, $V_{IN} > 2.4\text{V}$	-35		+35	mV
Line Regulation	V_{LINE}	$V_{OUT}+1\text{V} \leq V_{IN} \leq 7.0\text{V}$ $I_{OUT}=1\text{mA}$	-	0.2	0.3	%
Load Regulation	V_{LOAD}	$1\text{mA} \leq I_{OUT} \leq 100\text{mA}$ $V_{IN}=V_{OUT}+1\text{V}$	-	0.01	0.02	%
Dropout Voltage	V_D	$V_{OUT} > 3.0\text{V}$, $I_{OUT}=300\text{mA}$	-	300	-	mV
		$V_{OUT} > 3.0\text{V}$, $I_{OUT}=100\text{mA}$	-	80	-	mV
Enable input Threshold Voltage	V_{ENH}	Voltage Increasing Output Turns On	1.6	-	-	V
	V_{ENL}	Voltage Decreasing Output Turns Off	-	-	0.3	V
Output Noise	e_N			40		μV
Current Limit	I_{CL}		-	600	-	mA
Output Current (1)	I_{OUT}	$V_{OUT}+1\text{V} \leq V_{IN} \leq 7.0\text{V}$ $V_{IN} \geq 2.4$	300	-	-	mA
Quiescent Current	I_Q	$V_{IN}=V_{OUT}+1\text{V}$	-	60		μA
Short Circuit Current	I_{SC}	-		150		mA
Discharge Resistor	R_{DIS}	$V_{EN}=0\text{V}$		30	100	Ω
Discharge Time	T_{DIS}	$V_{OUT}=0\text{V}$ to 3.3V $C_{OUT}=1\mu\text{F}$		70	100	μs
Soft Start Time	T_{SS}	$V_{OUT}=3.3\text{V}$, $C_{SS}=47\text{nF}$ $C_{OUT}=1\mu\text{F}$		10		ms
Thermal Shutdown Temperature	T_{SD}	-	-	165	-	$^\circ\text{C}$
Thermal Shutdown Hysteresis	T_{HYS}	-	-	20	-	$^\circ\text{C}$
Ripple Rejection Ratio	R_A	$f=1\text{KHz}$, $I_{OUT}=10\text{mA}$, $C_{OUT}=1\mu\text{F}$	-	65	-	dB

NOTES: (1) Measured using a double sided board with 1 x 2 square inches of copper area connected to the GND pin for "heat spreading.

FUNCTION BLOCK DIAGRAM

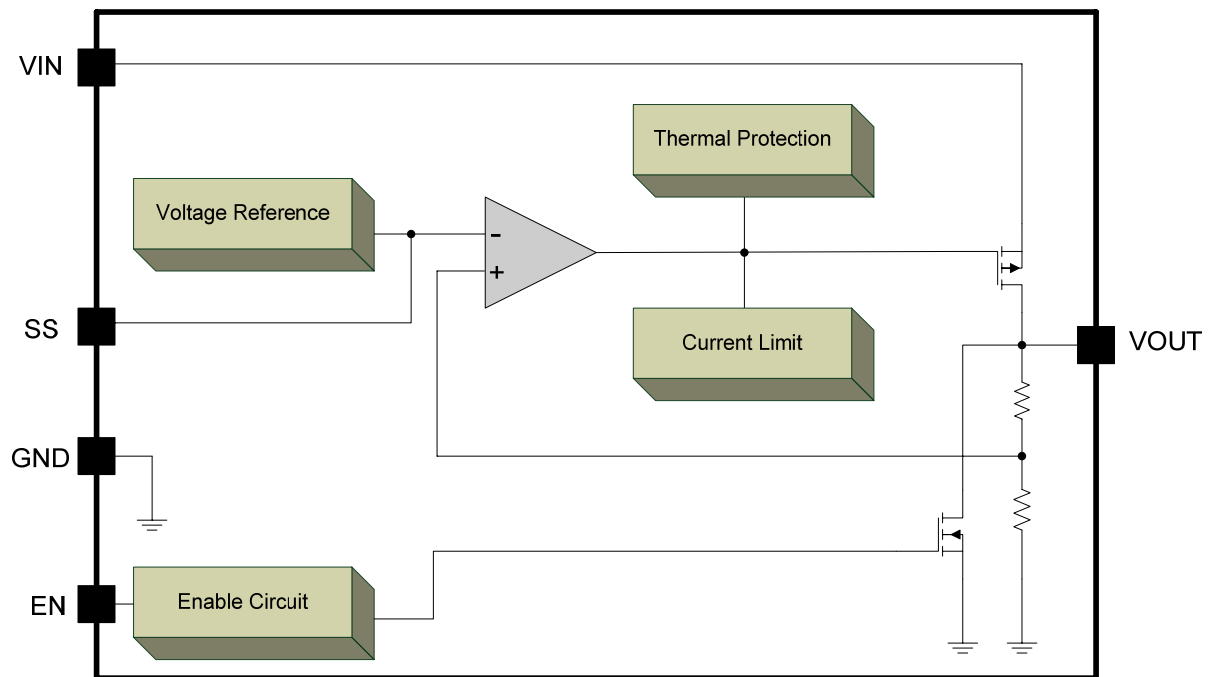

TYPICAL APPLICATIONS

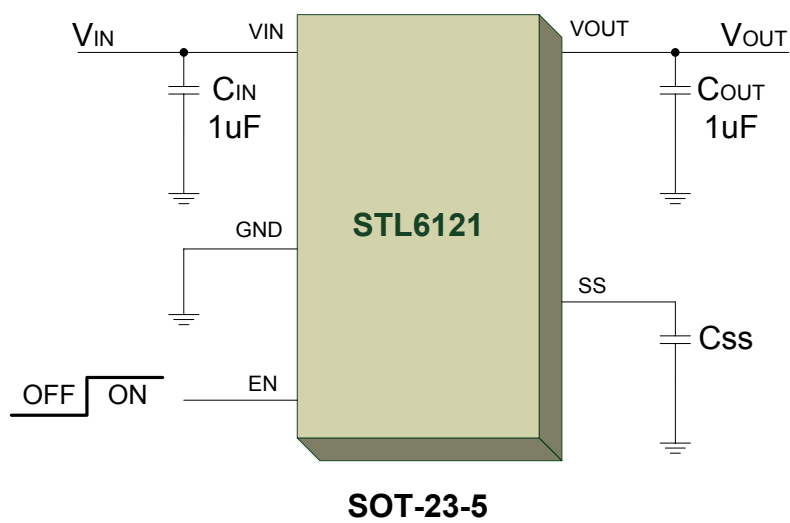

APPLICATION INFORMATION

◆ Detail Description

The STL6121 is a low-dropout linear regulator. The device provides preset 1.8V, 2.5V and 3.3V output voltages for output current up to 300mA. Other mask options for special output voltages are also available. As illustrated in function block diagram, it consists of a 0.95V bandgap reference, an error amplifier, a P-channel pass transistor and an internal feedback voltage divider.

The 0.95V bandgap reference is connected to the error amplifier, which compares this reference with the feedback voltage and amplifies the voltage difference. If the feedback voltage is lower than the reference voltage, the pass-transistor gate is pulled lower, which allows more current to pass to the output pin and increases the output voltage. If the feedback voltage is too high, the pass transistor gate is pulled up to decrease the output voltage.

The output voltage is feedback through an internal resistive divider connected to OUT pin. Additional blocks include an output current limiter, thermal sensor, and shutdown logic.

◆ Output Voltage Selection

For fixed voltage type of STL6121, the output voltage is preset at an internally trimmed voltage. The first two digits of part number suffix identify the output voltage (see Ordering Information). For example, the STL6121-33 has a preset 3.3V output voltage.

◆ Dropout Voltage

A regulator's minimum input-output voltage differential, or dropout voltage, determines the lowest usable supply voltage. In battery-powered systems, this will determine the useful end-of-life battery voltage. The STL6121 use a P-channel MOSFET pass transistor, its dropout voltage is a function of drain-to-source on-resistance $R_{DS(ON)}$ multiplied by the load current.

$$V_{DROP} = V_{IN} - V_{OUT} = R_{DS(ON)} \times I_{OUT}$$

◆ Current Limit

The STL6121 also includes a fold back current limiter. It monitors and controls the pass transistor's gate voltage, estimates the output current, and limits the output current within 600mA (Typ.)

◆ Internal P-channel Pass Transistor

The STL6121 features a P-channel MOSFET pass transistor. Unlike similar designs using PNP pass transistors, P-channel MOSFETs require no

base drive, which reduces quiescent current. PNP-based regulators also waste considerable current in dropout when the pass transistor saturates, and use high base-drive currents under large loads. The STL6121 does not suffer from these problems and consumes only 60 μ A (Typ.) of current consumption under heavy loads as well as in dropout conditions.

◆ Enable Function

EN pin starts and stops the regulator. When the EN pin is switched to the power off level, the operation of all internal circuit stops, the build-in P-channel MOSFET output transistor between pins VIN and VOUT is switched off, allowing current consumption to be drastically reduced. The VOUT pin enters the GND level through the internal discharge path between VOUT and GND pins.

◆ Soft Start Function

The capacitor can be connected between the SS pin and GND. This capacitor can be a low cost Polyester Film variety. A larger capacitor improves the AC ripple rejection, but also makes the output come up slowly. This "Soft" turn-on is desirable in some applications to limit turn-on surges.

◆ Fast Discharge Function

The STL6121 fixed type has fast discharge Function on EN pin disable. When user turns off the device, its internal pull-low resistor will discharge output capacitor charge. It'll avoid other device to arise wrong motions.

◆ Thermal Overload Protection

Thermal overload protection limits total power dissipation in the STL6121. When the junction temperature exceeds $T_J = +165^{\circ}\text{C}$, a thermal sensor turns off the pass transistor, allowing the IC to cool down. The thermal sensor turns the pass transistor on again after the junction temperature cools down by 20°C , resulting in a pulsed output during continuous thermal overload conditions.

Thermal overload protection is designed to protect the STL6121 in the event of fault conditions. For continuous operation, the absolute maximum operating junction temperature rating of $T_J = +125^{\circ}\text{C}$ should not be exceeded.

◆ Operating Region and Power Dissipation

Maximum power dissipation of the STL6121 depends on the thermal resistance of the case and circuit board, the temperature difference between the die junction and ambient air, and the rate of airflow. The power dissipation across the devices is

$P = I_{OUT} \times (V_{IN} - V_{OUT})$. The resulting maximum power dissipation is:

$$P_{MAX} = (T_J - T_A) / (\theta_{JC} + \theta_{CA}) = (T_J - T_A) / (\theta_{JA})$$

Where $(T_J - T_A)$ is the temperature difference between the STL6121 die junction and the surrounding air, θ_{JC} is the thermal resistance of the package chosen, and θ_{CA} is the thermal resistance through the printed circuit board, copper traces and other materials to the surrounding air. For better heat-sinking, the copper area should be equally shared between the IN, OUT, and GND pins.

If the STL6121 uses a SOT-23-5 package and this package is mounted on a double sided printed circuit board with two square inches of copper

allocated for "heat spreading", the resulting θ_{JA} is 250 °C/W.

Based on the maximum operating junction temperature 125 °C with an ambient of 25°C, the maximum power dissipation will be:

$$P_{MAX} = (T_J - T_A) / (\theta_{JC} + \theta_{CA}) \\ = (125 - 25) / 250 = 0.4W$$

Thermal characteristics were measured using a double sided board with 1" x 2" square inches of copper area connected to the GND pin for "heat spreading".

■ TYPICAL CHARACTERISTICS (25°C Unless Note)

Solf Start Function

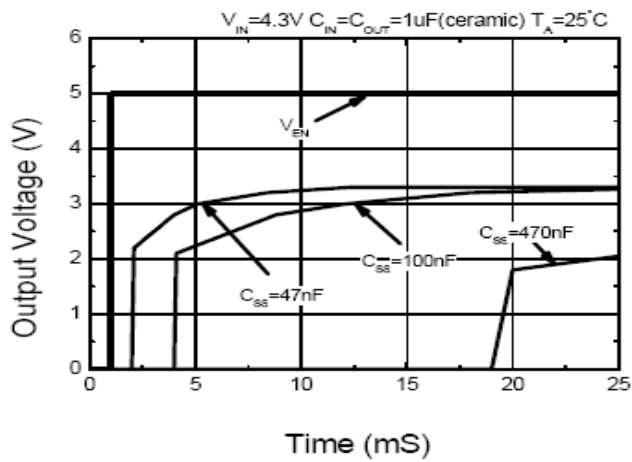

Supply Current VS Input Voltage

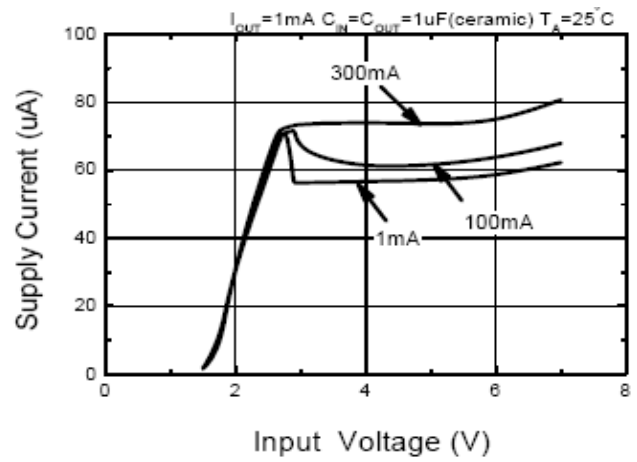

Output Voltage VS Input Voltage

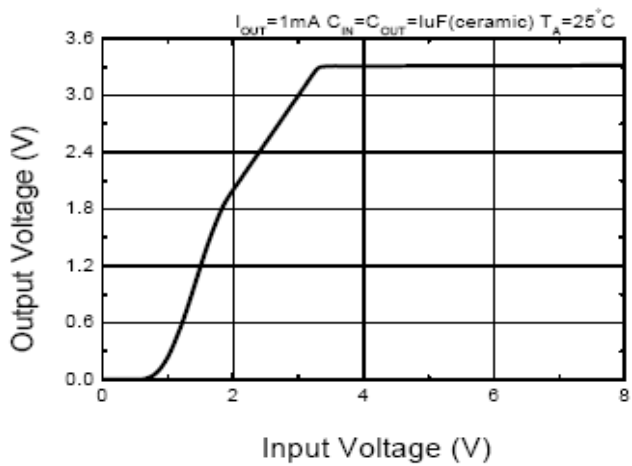

Dropout Voltage VS Output Current

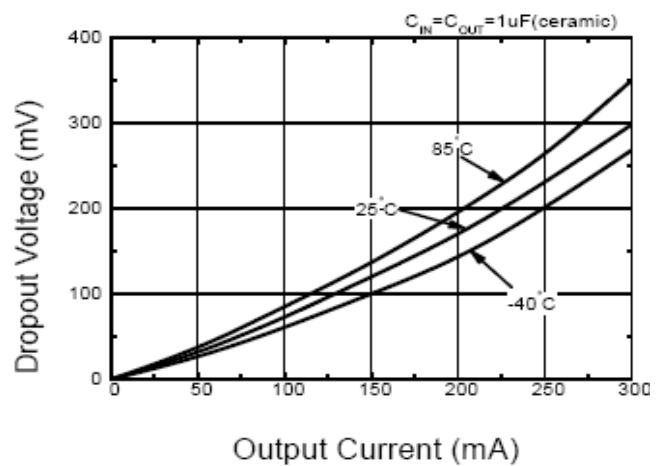

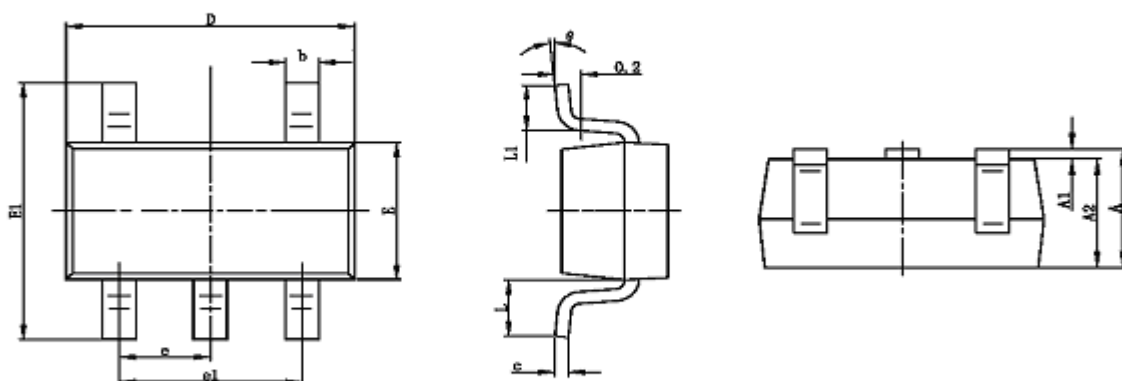
SOT-23-5 PACKAGE DIMENSIONS

Symbol	Dimensions In Millimeters		Dimensions In Inches	
	Min	Max	Min	Max
A	1.050	1.250	0.041	0.049
A1	0.000	0.100	0.000	0.004
A2	1.050	1.150	0.041	0.045
b	0.300	0.400	0.012	0.016
c	0.100	0.200	0.004	0.008
D	2.820	3.020	0.111	0.119
E	1.500	1.700	0.059	0.067
E1	2.650	2.950	0.104	0.116
e	0.950TYP		0.037TYP	
e1	1.800	2.000	0.071	0.079
L	0.700REF		0.028REF	
L1	0.300	0.600	0.012	0.024
θ	0°	8°	0°	8°